

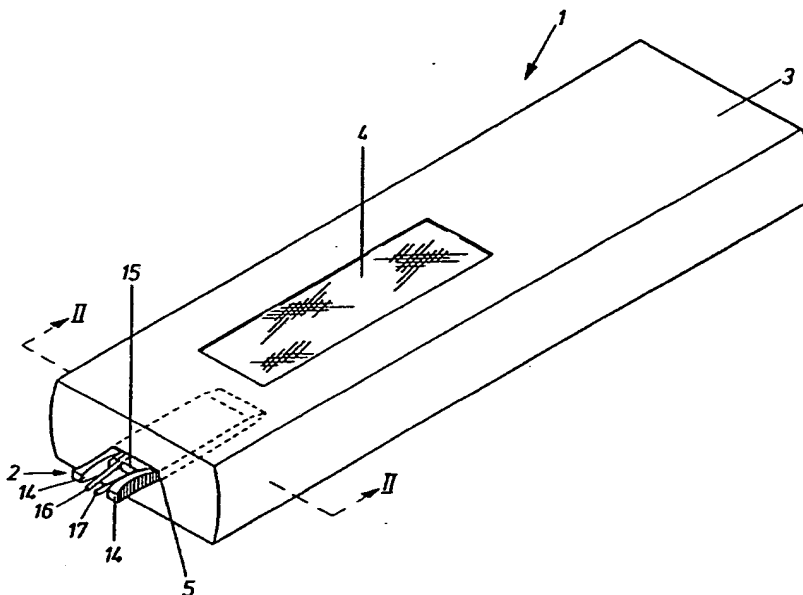

INTERNATIONAL APPLICATION PUBLISHED UNDER THE PATENT COOPERATION TREATY (PCT)

<p>(51) International Patent Classification⁴ : G01N 33/86, 21/03</p>	<p>A1</p>	<p>(11) International Publication Number: WO 89/ 06803 (43) International Publication Date: 27 July 1989 (27.07.89)</p>
<p>(21) International Application Number: PCT/DK88/00224 (22) International Filing Date: 29 December 1988 (29.12.88) (31) Priority Application Number: 157/88 (32) Priority Date: 14 January 1988 (14.01.88) (33) Priority Country: DK</p> <p>(71) Applicant (for all designated States except US): NOR-DISK GENTOFTE A/S [DK/DK]; Niels Steensensvej 1, DK-2820 Gentofte (DK).</p> <p>(72) Inventor; and (75) Inventor/Applicant (for US only) : PLUM, Thomas, Munk [DK/DK]; Skodsborgvej 414, 3.tv., DK-2942 Skodsborg (DK).</p> <p>(74) Agent: LARSEN & BIRKEHOLM A/S SKANDINAVISK PATENTBUREAU ; Skagensgade 64, DK-2630 Taastrup (DK).</p>	<p>(81) Designated States: AT, AT (European patent), AU, BB, BE (European patent), BG, BJ (OAPI patent), BR, CF (OAPI patent), CG (OAPI patent), CH, CH (European patent), CM (OAPI patent), DE, DE (European patent), DK, FI, FR (European patent), GA (OAPI patent), GB, GB (European patent), HU, IT (European patent), JP, KP, KR, LK, LU, LU (European patent), MC, MG, ML (OAPI patent), MR (OAPI patent), MW, NL, NL (European patent), NO, RO, SD, SE, SE (European patent), SN (OAPI patent), SU, TD (OAPI patent), TG (OAPI patent), US.</p> <p>Published <i>With international search report.</i> <i>In English translation (filed in Danish).</i></p>	
<p>(54) Title: APPARATUS FOR DETERMINATION OF THE COAGULATION TIME OF A BLOOD SAMPLE</p>		



(57) Abstract

With a blood measuring apparatus according to the invention, which uses capillary tubes (16, 17), these can be filled with blood from a drop of blood of about 1 microlitre. This small amount of blood can be produced by the pricking of a finger. The blood sample can then be placed in an apparatus (1) with equipment for the determination of the blood by transillumination. The tubes (16, 17) are mounted in an independent plate piece (6), and the tubes are secured in V-form so that the inlet ends lie closely up against each other. This provides the possibility of filling two tubes at the same time, and herewith the possibility of simultaneous determination of one's own blood and a comparison with blood in, for example, a prepared tube.

FOR THE PURPOSES OF INFORMATION ONLY

Codes used to identify States party to the PCT on the front pages of pamphlets publishing international applications under the PCT.

AT	Austria	FR	France	ML	Mali
AU	Australia	GA	Gabon	MR	Mauritania
BB	Barbados	GB	United Kingdom	MW	Malawi
BE	Belgium	HU	Hungary	NL	Netherlands
BG	Bulgaria	IT	Italy	NO	Norway
BJ	Benin	JP	Japan	RO	Romania
BR	Brazil	KP	Democratic People's Republic of Korea	SD	Sudan
CF	Central African Republic	KR	Republic of Korea	SE	Sweden
CG	Congo	LI	Liechtenstein	SN	Senegal
CH	Switzerland	LK	Sri Lanka	SU	Soviet Union
CM	Cameroon	LU	Luxembourg	TD	Chad
DE	Germany, Federal Republic of	MC	Monaco	TG	Togo
DK	Denmark	MG	Madagascar	US	United States of America
FI	Finland				

APPARATUS FOR DETERMINATION OF THE COAGULATION

TIME OF A BLOOD SAMPLE

The invention relates to an apparatus for the measuring of a blood sample, and comprising transparent
5 capillary elements for taking up the blood, and a housing-mounted photometer with measuring cells for the optical detection of the light permeability of the sample in the capillary element, and which is connected to a computer for the determination of the coagulation
10 tion time of the sample.

Apparatus of this kind is used particularly by haemophilia patients for measuring the coagulability of the blood, and hereby for the determination of
15 whether there is need for the injection of a factor VIII preparation in order to avoid haemorrhages.

Equipment of this kind is known from EP publication no. 120 715. Here, the capillary element consists
20 of a measuring cell in the form of an elongated channel at the end of a holder. Blood is sucked up into the channel, and the measuring cell can hereafter be inserted into a measuring apparatus with a light source and a photometer. The photometer
25 ures the amount of light which, after the emission, passes the transparent side of the measuring cell, and which after reflection in the blood and the back of the measuring cell again passes through the transparent side.

30

This measuring cell does not, however, provide an accurate measurement result, the reason being that it is based on reflection. This gives rise to a measurement inaccuracy which is so great that it is

unsuitable for the measurement of the coagulability of the blood. Furthermore, it is difficult to produce such a measuring cell, the reason being that the capillary element is built up of at least two parts which must be assembled for the formation of an element.

From the Swedish publication no. 404 260, an apparatus is known which can measure with greater accuracy, since this uses a beam of light and light detecting elements which are placed at an angle in relation to the light's direction of incidence in the sample.

However, this apparatus demands a precisely balanced positioning of these measuring means in relation to the blood sample, and in practice this means that the blood must be kept in a vessel-like container during the measurement. Since at a minimum there must be sufficient blood to cover the light detectors, a considerable amount of blood is required. This is a serious drawback for the user, the reason being that such a large amount of blood in practice can be obtained only with the help of a suction pump and hypodermic. Therefore, this apparatus is not suitable for so-called home use, where the user himself must be able to remove the blood sample necessary for a measurement.

It is the object of the invention to remedy these deficiencies and disadvantages of the known kinds of apparatus, and this is achieved by means of an apparatus where each capillary element constitutes a glass or a plastic tube, the inside diameter of

which is less than 0.5 mm.

The accuracy of measurement achieved hereby is considerably increased, since one can transilluminate
5 the blood in the tube transversely to said tube.
This reduces the measurement inaccuracy, the reason being that the tube can be produced with precise dimensions and of a homogenous material. This makes it well-suited for use in the measurement of the coag-
10 ulability of the blood.

Furthermore, for reasons of the small internal diameter of the tube, a considerably smaller amount of blood is required in relation to the known types of
15 measuring apparatus. For the filling of a tube length of, for example, 30 mm, less than 1 micro-
litre is required. In practice, a drop of blood procured by, for example, the pricking of a finger, could fill several tubes, which provides the possib-
20 ility of filling, for example, a prepared and an unprepared tube from one and the same drop of blood.

The apparatus thus becomes convenient to use, in that it is simple and quick to remove and take up a
25 drop of blood in the tubes for use in the measurement.

By mounting the tubes on an independent support element, e.g. in the form of a plate piece, as disclosed
30 in claim 2, the sample can easily be handled and filled, after which it can be placed in the measuring apparatus.

By providing openings in the support piece opposite

the tubes, as disclosed in claim 3, the passage of light through the blood will easily be ensured by placing light sources and detectors on each side of the opening in the apparatus.

5

By allowing the one end of the tubes to extend some distance outside the plate piece itself, as disclosed in claim 4, it will be a simple matter to place the tube ends in the drop of blood.

10

By allowing the tube ends to lie closely up against each other, as disclosed in claim 5, one will be able to fill several tubes from a single drop of blood.

15

By allowing the tubes to be placed in a fan-shaped manner, as disclosed in claim 6, it will be possible to transilluminate several tubes at a time in the apparatus, without any danger of the measurements
20 being mutually influenced.

By providing the support piece with an extension on each side around the tube ends, as disclosed in claim 7, one will be able to hold the element be-
25 tween two fingers, and also to use the extensions as support, for example against the skin of the finger, during the taking up of the blood.

Finally, it is expedient, as disclosed in claim 8,
30 to be able to insert the element directly into a slot in the measuring apparatus, in that the positioning of the tube in relation to the photo element will then always be ensured.

The invention will now be described in closer detail with reference to the drawing, where

- 5 Fig. 1 shows a perspective illustration of an apparatus with support element inserted,
- Fig. 2 shows a cross-sectional drawing of the apparatus seen in the direction II-II in fig. 1,
- 10 Fig. 3 shows the support element seen from the side during the filling of the tubes from a finger,
- 15 Fig. 4 shows the support element seen from the opposite side,
- Fig. 5 shows a block diagram of the measuring equipment in the apparatus,
- 20 Fig. 6 shows a graph of the translucency D in normal blood as a function of the time t , and
- 25 Fig. 7 shows a corresponding graph for the blood of a haemophilia patient.

In fig. 1 is shown an example of a preferred embodiment of an apparatus according to the invention.

30

The measuring apparatus itself is indicated as a whole by the reference figure 1. It comprises a housing 3 with a display 4 on the one side.

At the one end of the housing 3 there is provided a slot opening 5 in which a support element with capillary tubes, which is shown as a whole by the reference figure 2, can be inserted, as shown in fig.

5 1.

As shown in fig. 2, one or more light sources 7, 9, preferably in the form of light diodes, are mounted in the one part of the housing 3 in relation to the
10 slot opening 5, plus a light meter, preferably in the form of a photodiode 8, 10, is mounted in the other part of the housing in relation to the slot opening.

The apparatus is also provided with a built-in but
15 not shown microprocessor, which is connected as illustrated in the block diagram shown in fig. 5.

In this diagram, the apparatus itself is indicated by the block 22, which is connected to an analog/
20 digital converter 23 which converts the signal from the photodiodes 8, 10 to a figure which is read into a microprocessor 24. This is arranged to analyse the signal from the measurement and to supply pulses to a display 25 on the apparatus, which in fig. 1 is
25 indicated by the reference figure 4.

By depicting the signal from this photometer as a function of time, a diagram as shown in figs. 6 and 7 is obtained.

30

Blood with a normal coagulation characteristic will, after a period of time, in the example in fig. 6 after approx. 5 mins., show a markedly decreasing light permeability for reasons of the coagulation of

the blood.

As shown in fig. 7, such a marked decrease does not appear with blood from a haemophilia patient.

5

Therefore, the blood's permeability to light can be used for the determination of the coagulation time, and hereby for indication of the need for an injection of a factor VIII preparation.

10

When a blood sample is thus placed in a capillary element between the light sources 7, 9 and the photodiodes 8, 10 in an apparatus 1, from the display 4 one will be able to read the period of time which it takes for the blood to begin to coagulate, and which corresponds to the turning point in the graph shown in fig. 6.

As shown in figs. 3 and 4, the capillary element according to the invention comprises a support piece 6, which is preferably made of an opaque plastic. This is in the form of a plate which, as shown at its one end, is tapered to form a wedge 13 for easy insertion into the slot 5 in the apparatus.

25

At the opposite end of the plate piece, a pair of extensions are provided in the form of legs 14, the outer sides of which are slightly concave and provided with small serrations for easy handling during operation.

30

Moreover, the top and bottom sides of the plate piece are provided with a pair of grooves or guide tracks 11, 12 to ease the guiding of the plate dur-

ing insertion into the apparatus.

Finally, on the one side there are formed two recesses which extend at a mutual angle, and in which a
5 glass or plastic capillary tube 16, 17 can be secured, for example by glueing. Moreover, at a suitable place in each recess there is a through-going opening 18, 19.

10 When the support element 2 is inserted in the apparatus, the openings 18, 19 must be placed precisely opposite the light diodes and the photodiodes as shown in fig. 2.

15 As shown in figs. 3 and 4, the capillary tubes 16, 17 project for a distance beyond the plate edge 15, and also a small distance beyond the ends of the legs 14.

20 Glass is well-suited for the tube, the reason being that its electro-negative characteristics ensure a uniform starting time for the coagulation of the blood. Furthermore, an internal diameter of about 0.2
25 mm will be sufficient to ensure that the result of the measurement is reliable. If the glass has a length of approx. 30 mm, its capacity will be about 1 microlitre. It is of great importance that more blood is not demanded, in that one can hereby carry out a blood test on the basis of a single drop of
30 blood.

As shown in fig. 3, the blood sample can be taken from a drop 21 on a finger 20, which is first pricked e.g. by means of a not-shown lancet. When the drop of

blood has been formed, the support element 2, held by means of two fingers against the legs 14, is brought to bear against the finger so that the ends of the tubes 16, 17 are dipped in the blood. Here-
5 after, blood is taken up into the tubes 16, 17 in such an amount that it fills out the tubes opposite the openings 18, 19.

The support element 2 is then conveyed to the meas-
10 uring apparatus, where it is inserted in the opening 5.

After the insertion, the measuring procedure commences and, after a short period of time, the measuring
15 apparatus registers the time at which the coagulation starts, and shows this time on the display 4. In this simple manner, the patients themselves can measure their blood and decide whether there is need for an injection.

20

Where the user has difficulty in handling the relatively small support element 2, it can be of advantage to insert the element into the measuring apparatus before taking the blood sample, and there-
25 after apply the apparatus and therewith the support element with the tubes down on the drop of blood. In this way, one can more easily handle and control the support element while taking the blood sample.

30 After the measurement, the support element with the blood sample can be removed and discarded, in that the support element is a disposable product to simplify the operation and at the same time ensure the greatest possible hygiene.

One of the tubes 16, 17 can be provided with an internal coating of a material, e.g. a factor VIII preparation, the concentration of which is desired to be measured in the blood and compared with that
5 blood which has been taken up into the second tube. This second tube is not provided with an internal coating, and is therefore a dry tube which will contain the patient's own blood. A patient can hereby simultaneously determine his blood's factor VIII
10 concentration.

In the foregoing, the displaying of the result of the measurement has been discussed only in the form of a time-related indication, but it lies within the
15 scope of the invention to use other corresponding parameters for the determination of factors which are of importance for the result of the analysis.

20

25

30

C L A I M S

1. Apparatus for the measuring of a blood sample, and comprising transparent capillary elements for
5 the taking up of the blood, and also a housing-mounted photometer with measuring cells for the optical detection of the light permeability of the sample in the capillary element, and which is connected to a computer for the determination of the sample's co-
10 agulation time, c h a r a c t e r i z e d in that each of the capillary elements consists of a glass or plastic tube (16, 17), the inside diameter of which is less than 0.5 mm.
- 15 2. Apparatus according to claim 1, c h a r a c t e r i z e d in that the tubes (16, 17) are mounted in an independent support piece (6) in relation to the photometer.
- 20 3. Apparatus according to claims 1 and 2, c h a r a c t e r i z e d in that the support piece (6) is provided with an opening (18, 19) opposite each tube (16, 17).
- 25 4. Apparatus according to claims 1-3, c h a r a c t e r i z e d in that the inlet ends of the tubes (16, 17) extend for a distance beyond the side edge (15) of the support piece (6).
- 30 5. Apparatus according to claim 4, c h a r a c t e r i z e d in that inlet ends lie closely up against each other.
6. Apparatus according to claims 1-5, c h a r a c t e r i z e d in that the inlet ends of the tubes (16, 17) are mounted in an independent support piece (6) in relation to the photometer.

t e r i z e d in that the tubes (16, 17) are placed in a fan-shaped manner.

7. Apparatus according to claims 2-6, c h a r a c -
5 t e r i z e d in that the support piece (6) is pro-
vided with a pair of fingergrrips in the form of legs
(14) which extend from the side edge (15) of the
support piece (6) on each side of the tubes (16,
17).

10

8. Apparatus according to claims 2-7, c h a r -
a c t e r i z e d in that the support element (2)
can be inserted into an opening (5) in the photo
element's (1) housing (3).

15

20

25

30

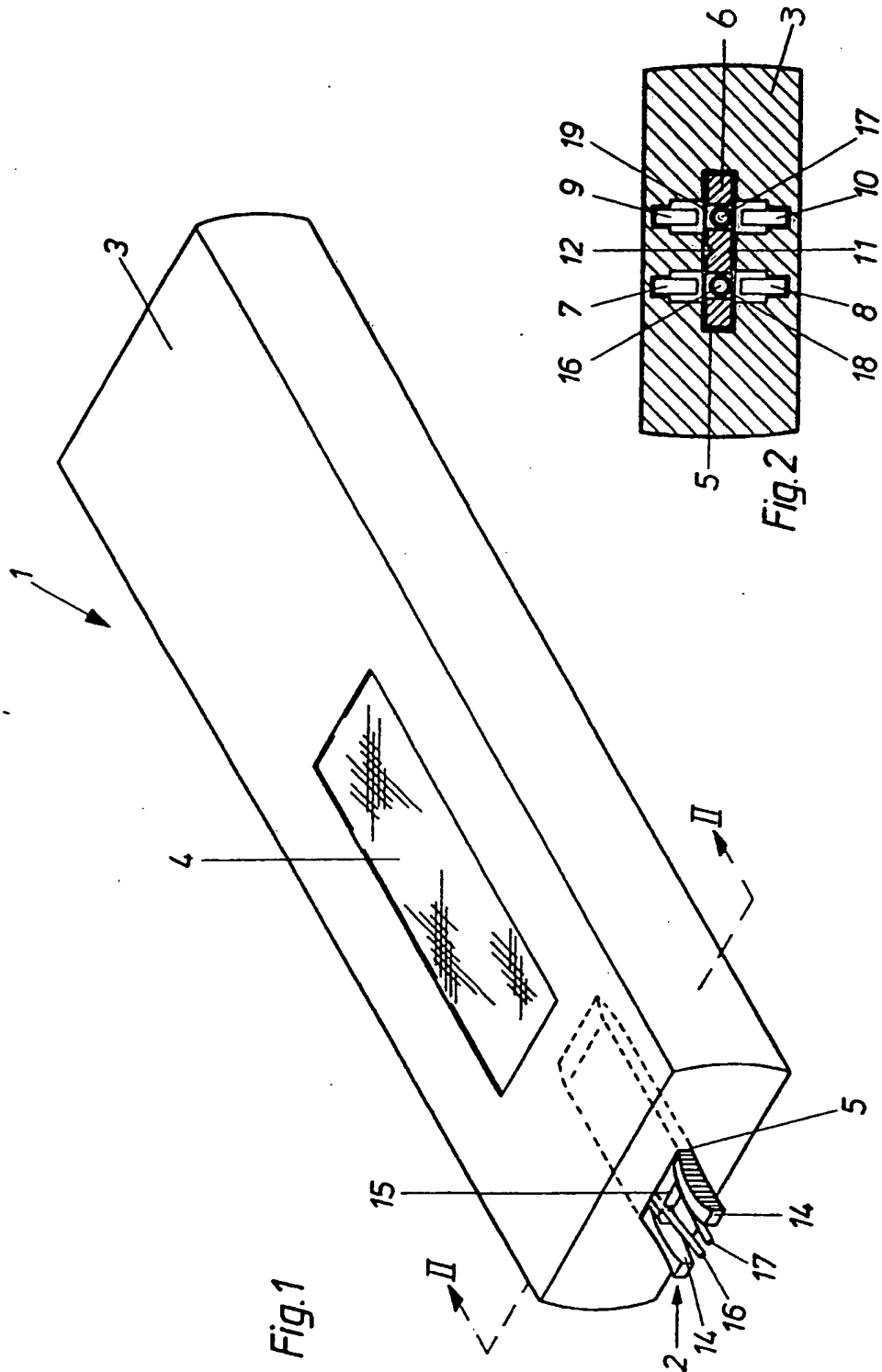

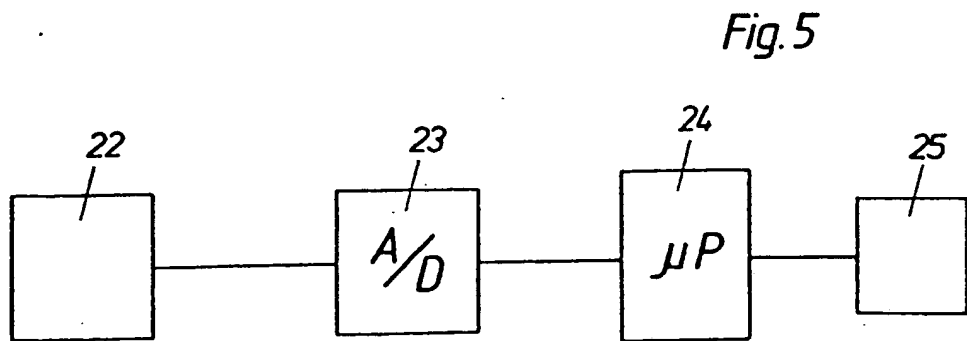
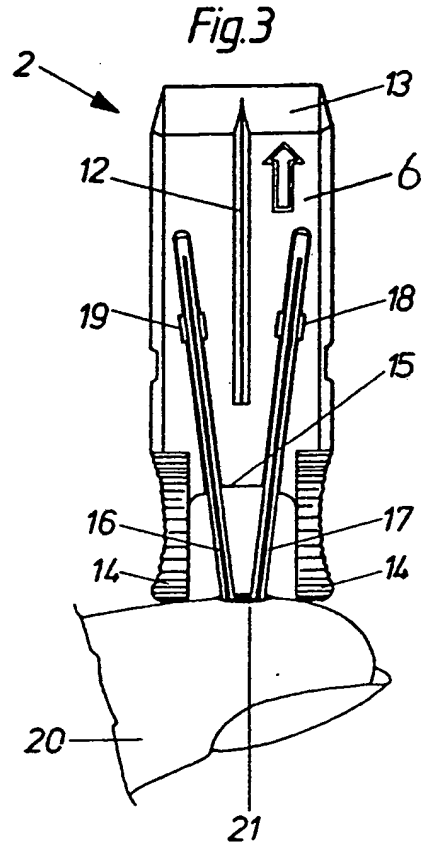
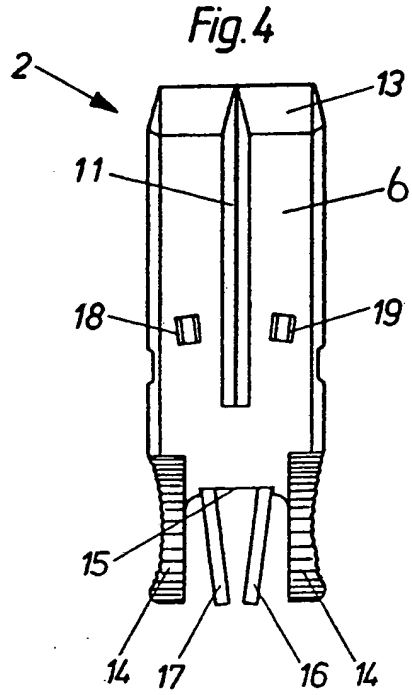

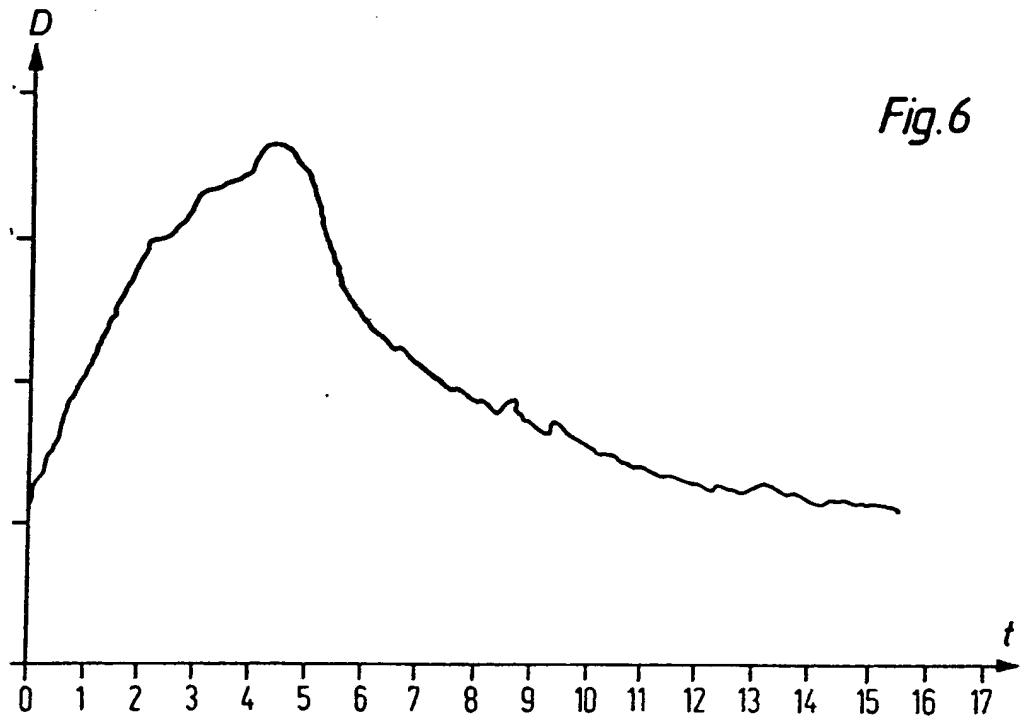

Fig. 6

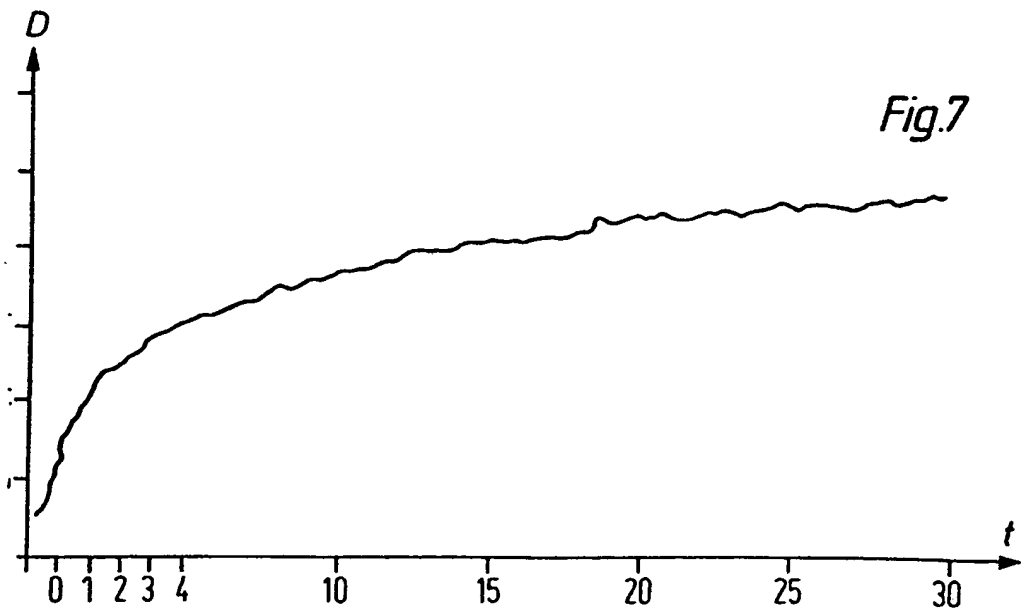
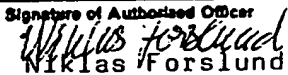

Fig. 7

INTERNATIONAL SEARCH REPORT

International Application No PCT/DK88/00224

I. CLASSIFICATION OF SUBJECT MATTER (if several classification symbols apply, indicate all) ⁸		
According to International Patent Classification (IPC) or to both National Classification and IPC ₄		
G 01 N 33/86, G 01 N 21/03		
II. FIELDS SEARCHED		
Minimum Documentation Searched ⁷		
Classification System	Classification Symbols	
	IPC 4 : G 01 N; C 12 M; C 12 Q	
Documentation Searched other than Minimum Documentation to the Extent that such Documents are Included in the Fields Searched ⁸		
SE, NO, DK, FI classes as above.		
III. DOCUMENTS CONSIDERED TO BE RELEVANT ⁹		
Category ⁹	Citation of Document, ¹¹ with indication, where appropriate, of the relevant passages ¹²	Relevant to Claim No. ¹³
Y	A Wiley Biomedical Publication, 1976, Vurek, G, Bowman, R, "Assay Methods Using Capillary Tubes", Mario Werner, M.D., John Wiley & Sons pp 55-64. See in particular p 59, col 1, lines 15-28	1
Y	EP, A2, 0 120 715 (HYSLOP, CHRISTOPHER PAUL) 3 October 1984 See in particular the abstract.	1
Y	SE, B, 404 260 SWELAB INSTRUMENT AB) 25 September 1978 See in particular the claims and the figure	1
<p>⁹ Special categories of cited documents: ¹⁰</p> <p>"A" document defining the general state of the art which is not considered to be of particular relevance</p> <p>"E" earlier document but published on or after the international filing date</p> <p>"L" document which may throw doubts on priority claim(s) or which is cited to establish the publication date of another citation or other special reason (as specified)</p> <p>"O" document referring to an oral disclosure, use, exhibition or other means</p> <p>"P" document published prior to the international filing date but later than the priority date claimed</p> <p>"T" later document published after the international filing date or priority date and not in conflict with the application but cited to understand the principle or theory underlying the invention</p> <p>"X" document of particular relevance; the claimed invention cannot be considered novel or cannot be considered to involve an inventive step</p> <p>"Y" document of particular relevance; the claimed invention cannot be considered to involve an inventive step when the document is combined with one or more other such documents, such combination being obvious to a person skilled in the art.</p> <p>"A" document member of the same patent family</p>		
IV. CERTIFICATION		
Date of the Actual Completion of the International Search	Date of Mailing of this International Search Report	
1989-04-07	1989-04-17	
International Searching Authority	Signature of Authorized Officer	
Swedish Patent Office	 Niklas Forslund	